

Model	Dimensions (mm)						Weight Kg	Maximum Torque		Square Drive
	A	B	C	D	E	R		lbf.ft	Nm	
CR 1	42	115	28	65	70	24	4	1,000	1,360	3/4"
CR 1.5	50	140	30	65	90	25	6	1,500	2,040	1"
CR 3	52	175	40	90	92	35	8	3,300	4,488	1"
CR 5	65	180	45	95	120	37	13	5,800	7,888	1 1/2"
CR 7	65	207	58	112	120	45	16	7,400	10,060	1 1/2"
CR 11	83	222	66	130	138	45	22	11,000	14,960	1 1/2"
CR 15	95	230	70	140	172	52	31	15,000	20,400	2 1/2"
CR 20	97	265	74	157	175	62	44	21,000	28,560	2 1/2"
CR 30	115	290	80	175	185	69	54	32,000	43,520	2 1/2"
CR 50	145	320	90	200	230	85	103	50,000	68,000	3 1/2"
CR 80	172	416	100	258	272	100	178	80,000	108,800	3 1/2"

• No statement or data within this literature is warranted or guaranteed to be accurate.

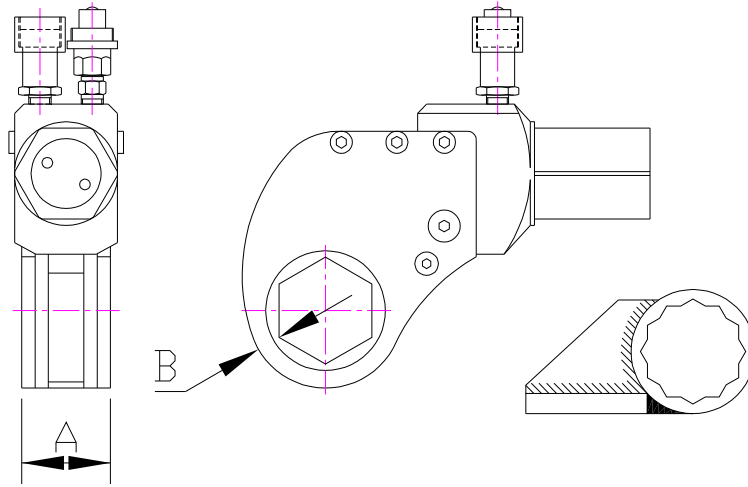

Model	Dimensions (mm)		Maximum A/F		Maximum Torque	
	A	B	inch	mm	lbf.ft	Nm
CCR 1	38	11	1 13/16"	41	1,000	1,360
CCR 1.5	41	12	2 3/16"	55	1,500	2,040
CCR 3	52	15	2 9/16"	65	3,300	4,488
CCR 5	58	16	3"	75	5,800	7,888
CCR 7	64	18	3 1/8"	80	7,400	10,060
CCR 11	82	20	4 5/8"	120	11,000	14,960
CCR 15	96	22	4 5/8"	120	15,000	20,400
CCR 20	100	25	5"	130	21,000	28,560
CCR 30	120	30	6 1/8"	155	32,000	43,520
CCR 50	147	38	8"	205	50,000	68,000
CCR 80	180	48	10"	250	80,000	108,000

• No statement or data within this literature is warranted or guaranteed to be accurate.