

THE WEDGE

**HIRE, SALES
& ADVICE**
01709 550088

Flange Spreading Wedges

FLANGE SPREADING WEDGES



FUNCTIONAL

The Flange Spreaders can be used during:

- Commissioning
- Construction
- Routine maintenance
- Shutdowns/outages
- Testing
- Valve change-outs

SPECIAL FEATURES

- Unique interlocking first step
- Deep 15mm secure hold on first step
- Requires access gap of only 6mm
- Robust lightweight tool
- Automatic mechanical retraction
- Environmentally friendly

OPERATING BENEFITS

- Secure hold on each step
- Quick and easy operation
- Saves time
- Safe operation
- Portable

Mechanical Flange Spreader

Spreading Force: = 9.4 T (94 kN)

Kit components:

- 1 x WC9TM Wedgehead
- 1 x Torque wrench with 22 mm socket
- 1 x Safety block
- 1 x Instruction manual
- 1 x Cardboard packaging



Integral Hydraulic Flange Spreader

Spreading Force: = 14.5 T (145 kN)

Kit components:

- 1 x WC14.5T Wedgehead
- 1 x 10,000 psi (700 bar) 10 T integral hydraulic pump/cylinder
- 1 x Safety block
- 1 x Carry strap
- 1 x Instruction manual
- 1 x Robust carry case



Hydraulic Flange Spreader

Spreading Force: = 15.5 T (155 kN)

KIT OPTIONS:

- See next page for kit options and components.
- Mini Kit
- Standard Kit
- Maxi Kit



It is recommended that tools are used in pairs

ACCESSORIES

- 2 x stepped blocks
- 2 x M6 x 10mm countersunk screws
- 1 x 4mm hex. key



Lesser penetration, greater spread
Sold in pairs

Call for **PRICES** or a **FREE DEMONSTRATION** on:
01709 550088



The Wedge



MINI KIT COMPONENTS

- 1 x WC15TE Wedgehead
- 1 x 10,000 psi Hydraulic Cylinder
- 1 x Safety Block
- 1 x Instruction Manual

STANDARD KIT COMPONENTS

- 1 x WC15TE Wedgehead
- 1 x Pair of Stepped Blocks
- 1 x 10,000 psi 2m Hydraulic Hose
- 1 x 10,000 psi Hydraulic Cylinder
- 1 x 10,000 psi HP350S Sealed Hand Pump with Gauge
- 1 x Safety Block
- 1 x Instruction Manual
- 1 x Robust Carry Case

MAXI KIT COMPONENTS

- 2 x WC15TE Wedge Heads
- 2 x Pairs of Stepped Blocks
- 2 x 10,000 psi 2m Hydraulic Hoses
- 2 x 10,000 psi Hydraulic Cylinders
- 1 x 10,000 psi HP350D Sealed Hand Pump with Gauges
- 2 x Safety Blocks
- 1 x Instruction Manual
- 1 x Robust Carry Case



TOOL DIMENSIONS - CLOSED

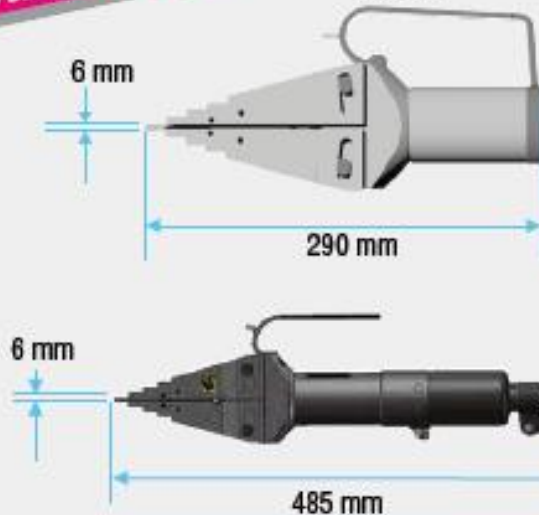

TOOL DIMENSIONS - OPEN

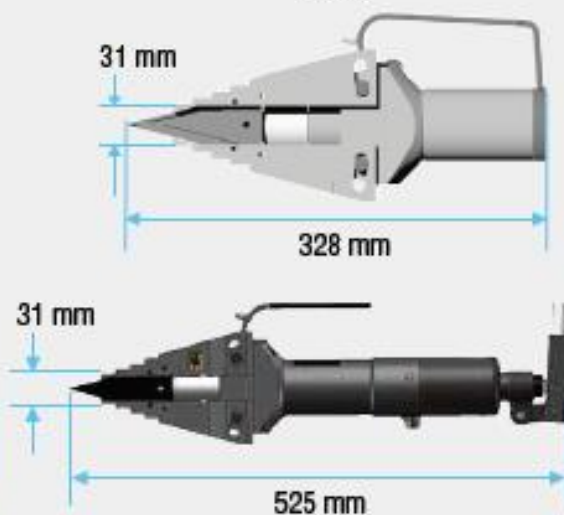

Other Product Ranges Available

Flange Alignment Tools



Zero-Gap Spreading Tools



Hydraulic Vertical Lifting Wedge



Mini Gap Flange Spreader

